

**BRACKET "F"**  
**(1) REQD**

TOTAL QTY	UNIT QTY	PART ID	DESCRIPTION	LENGTH	WEIGHT EACH PRT	WEIGHT EACH UNIT	TOTAL WEIGHT	REMARKS(GRADE)
1			Bracket "F"					
2	2	p1	PL3/8" x 6"	0'-7"	4.46	8.92	8.92	A36
2	2	p2	PL3/8" x 2"	0'-7"	2.23	4.46	4.46	A36
1	1	p3	PL1/4" x 1 1/4"	0'-8"	0.34	0.34	0.34	A36
1	1	p4	PL3/8" x 2"	0'-3"	0.20	0.20	0.20	A36
1	1	p6	4" SCH 40	0'-1"	0.89	0.89	0.89	A500 Gr B
			TOTALS			14.81	14.81	

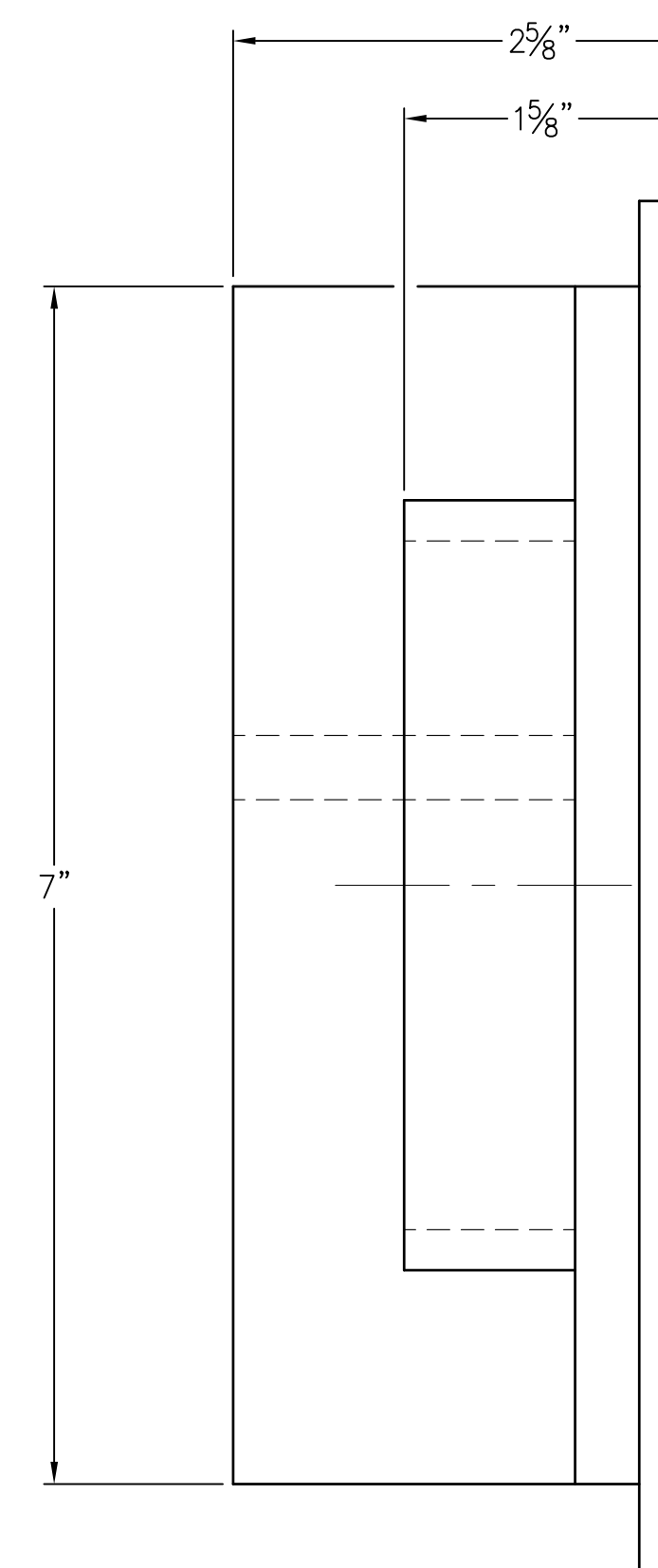

- NOTES: 1. ALL WELDING TO BE FCAW  
 2. ALL WELD PROGRESSION IS UP  
 3. WELDMENT TO BE TACKED TOGETHER PRIOR TO HANGING IN VERTICAL POSITION  
 4. WELDMENT NUMBER SHALL BE IN UPPER RIGHT CORNER

ACAD/FILE: Bracket F  
 DRAWN BY: VFR 4/12/2017  
 CHECKED BY: initials xx/xx/2015  
 APPROVED BY: initials xx/xx/2015

**MORAN IRON WORKS, INC.**  
 11739 HWY. M-68 ONAWAY, MI 49765  
 1-989-733-2011

Industrial Arts Institute  
 Bracket  
 Onaway, MI.

REVISION NO.	REVISION DESCRIPTION
1	initials == DATE: xx/xx/xxxx
PROJECT MANAGER	PROJECT NUMBER
Keith Raymond	000000
SHEET TITLE	
Bracket "F"	
SHEET	
1 of 1	

TOTAL QTY	UNIT QTY	PART ID	DESCRIPTION	LENGTH	WEIGHT EACH PRT	WEIGHT EACH UNIT	TOTAL WEIGHT	REMARKS(GRADE)	
1			Bracket "G"						
2	2	p1	PL3/8" x 6"	0'-7"	4.46	8.92	8.92	A36	
2	2	p2	PL3/8" x 2"	0'-7"	2.23	4.46	4.46	A36	
1	1	p4	PL3/8" x 2"	0'-3"	0.20	0.20	0.20	A36	
1	1	p6	4" SCH 40	0'-1"	0.89	0.89	0.89	A500 Gr B	
TOTALS							14.47	14.47	

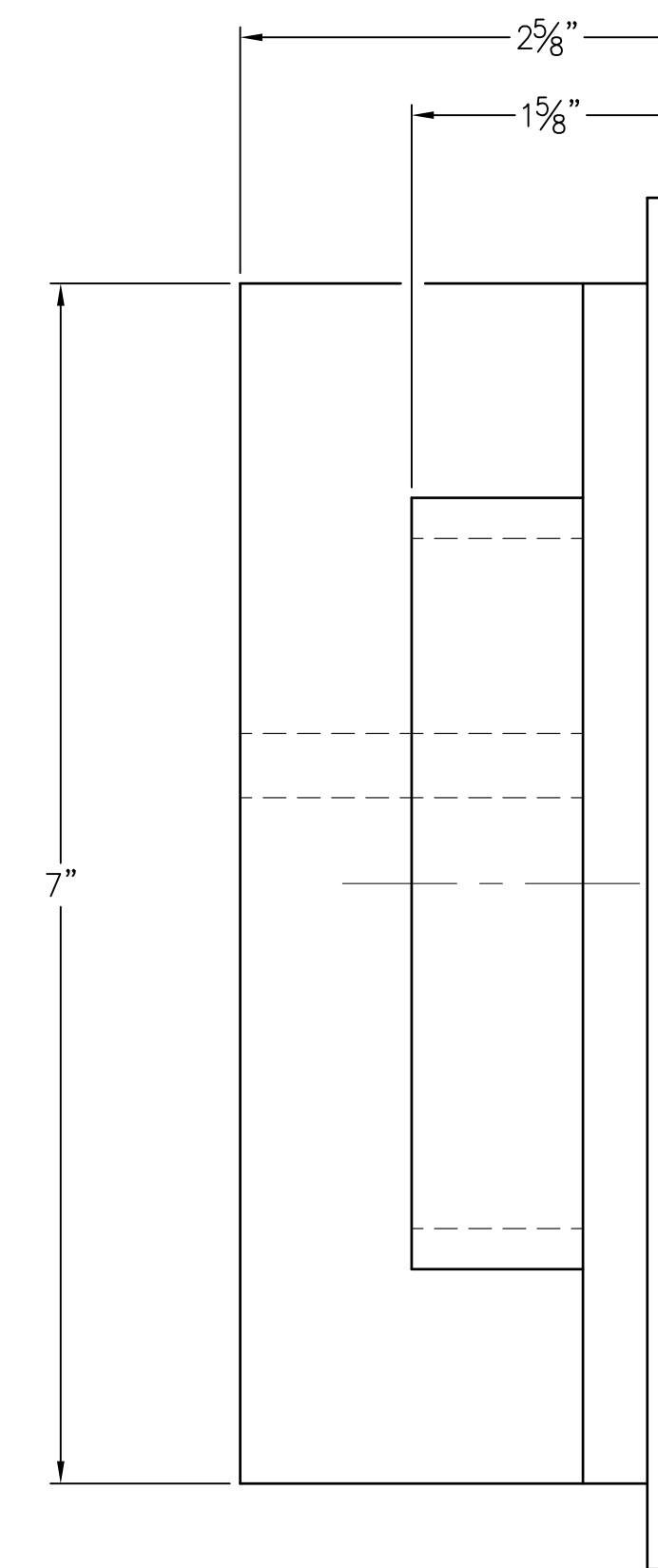
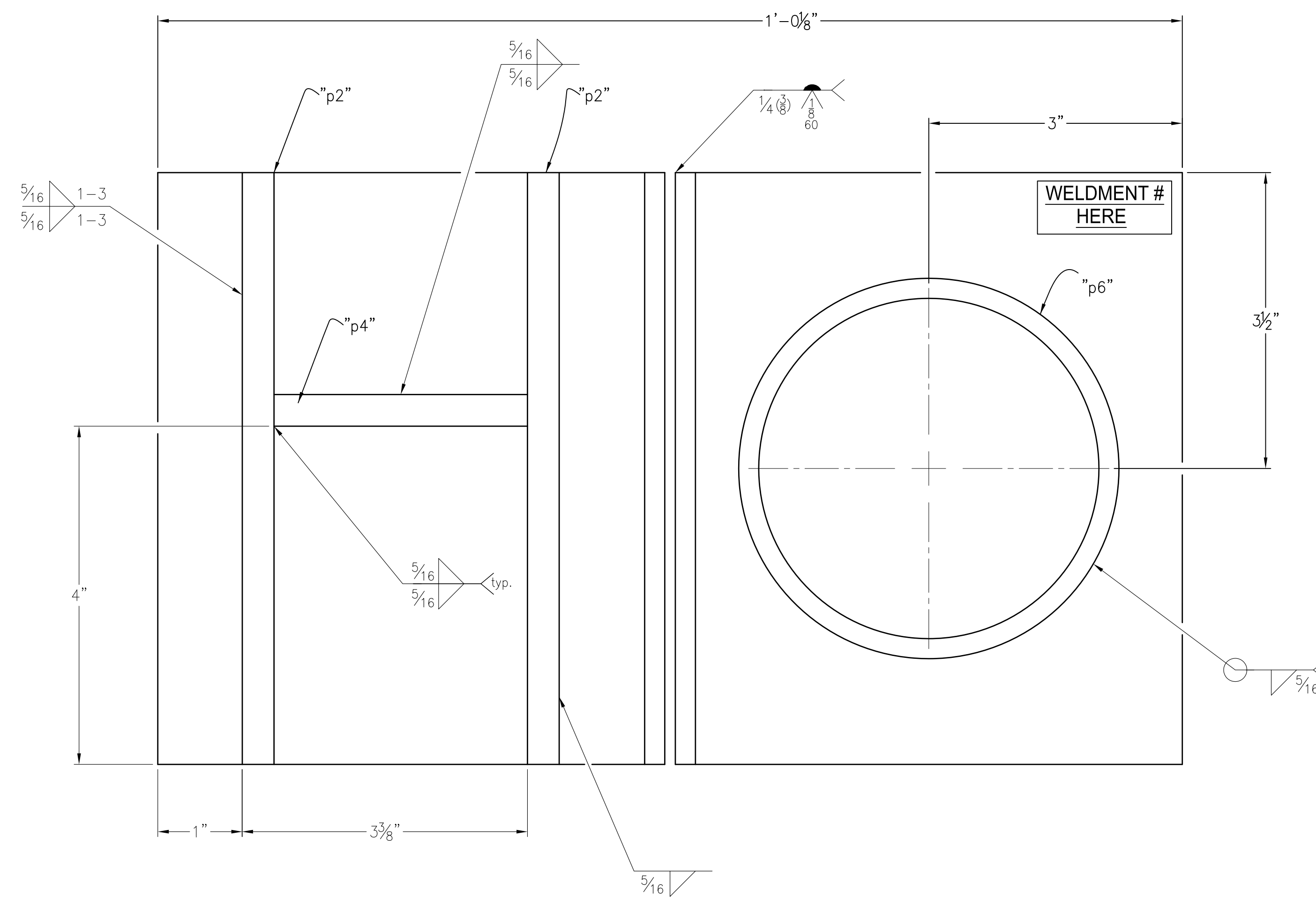
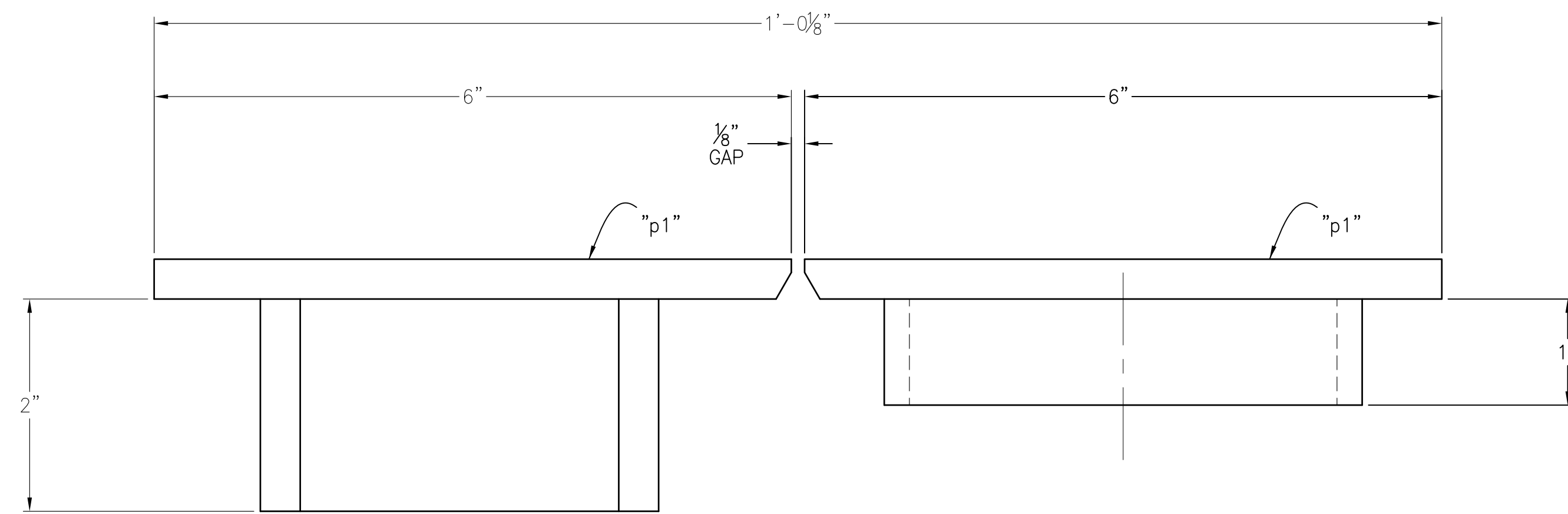

BRACKET "G"  
(1) REQD

- NOTES: 1. ALL WELDING TO BE GMAW  
 2. ALL WELD PROGRESSION IS UP  
 3. WELDMENT TO BE TACKED TOGETHER PRIOR TO HANGING IN VERTICAL POSITION  
 4. WELDMENT NUMBER SHALL BE IN UPPER RIGHT CORNER

ACAD/FILE: Bracket G  
 DRAWN BY: VFR 4/12/2017  
 CHECKED BY: initials xx/xx/2015  
 APPROVED BY: initials xx/xx/2015

**MORAN IRON WORKS, INC.**  
 11739 HWY. M-68 ONAWAY, MI 49765  
 1-989-733-2011

Industrial Arts Institute  
 Bracket  
 Onaway, MI.

REVISION NO.	REVISION DESCRIPTION
1	initials == DATE: xx/xx/xxxx
PROJECT MANAGER	PROJECT NUMBER
Keith Raymond	000000
SHEET TITLE	
Bracket "G"	
SHEET	
1 of 1	

TOTAL QTY	UNIT QTY	PART ID	DESCRIPTION	LENGTH	WEIGHT EACH PRT	WEIGHT EACH UNIT	TOTAL WEIGHT	REMARKS(GRADE)
1			Bracket "S"					
1	2	p1	PL3/8" x 6"	0'-7"	2.23	4.46	2.23	A36
1	1	p2	PL3/8" x 2"	0'-5"	2.97	2.97	2.97	A36
1	1	p3	PL3/8" x 2"	0'-4"	0.89	0.89	0.89	A500 Gr B
1	1	p4	4" SCH 40	0'-1"	0.89	0.89	0.89	
			TOTALS			9.21	9.21	

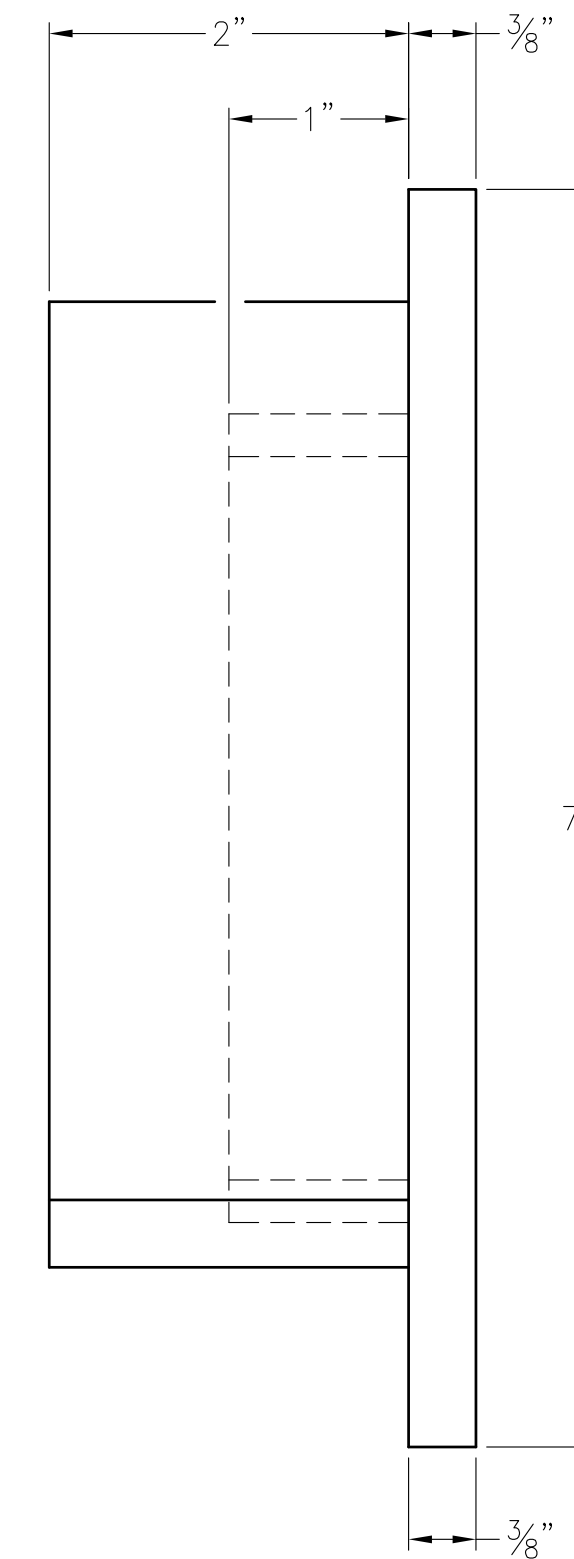
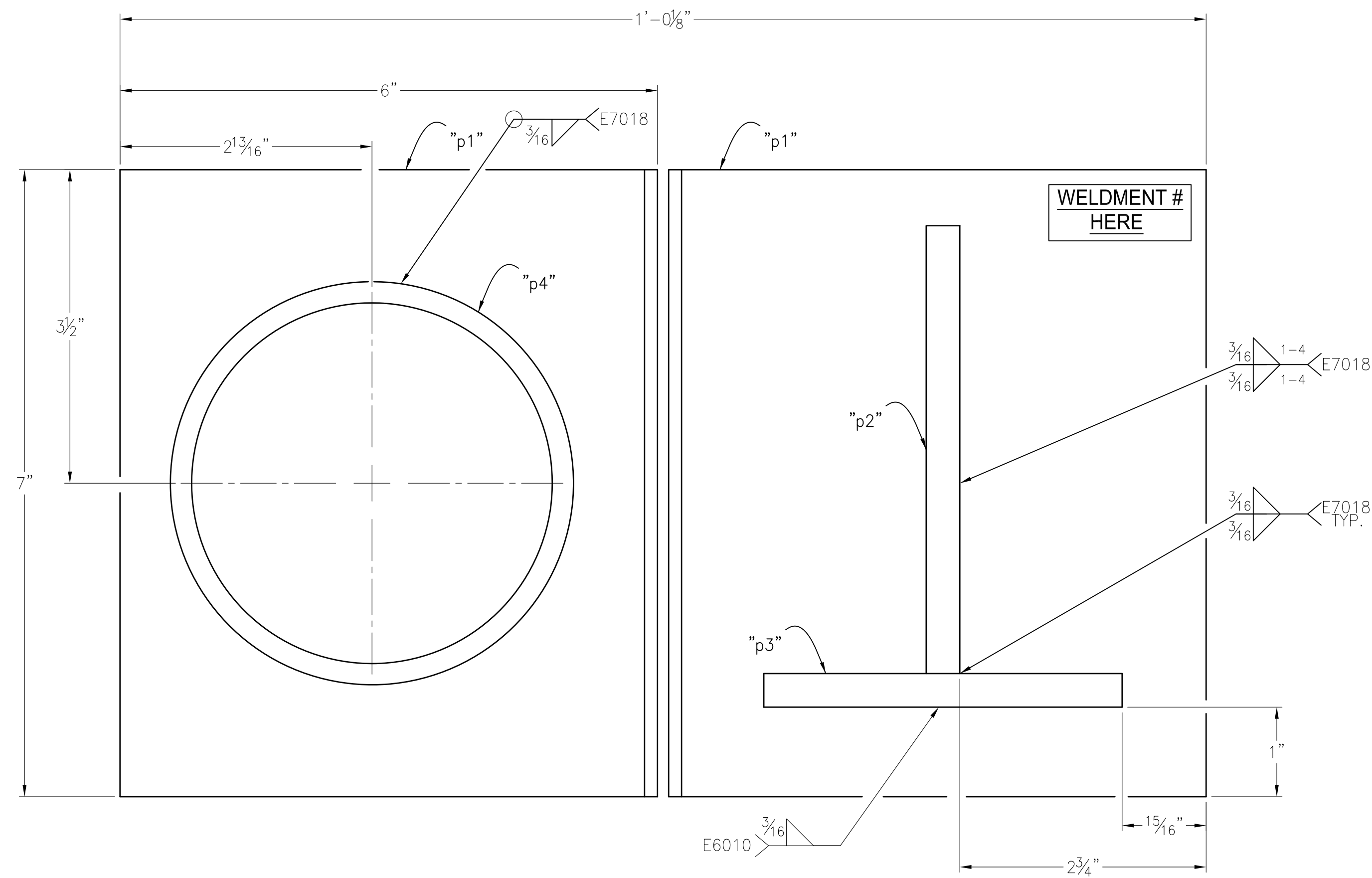
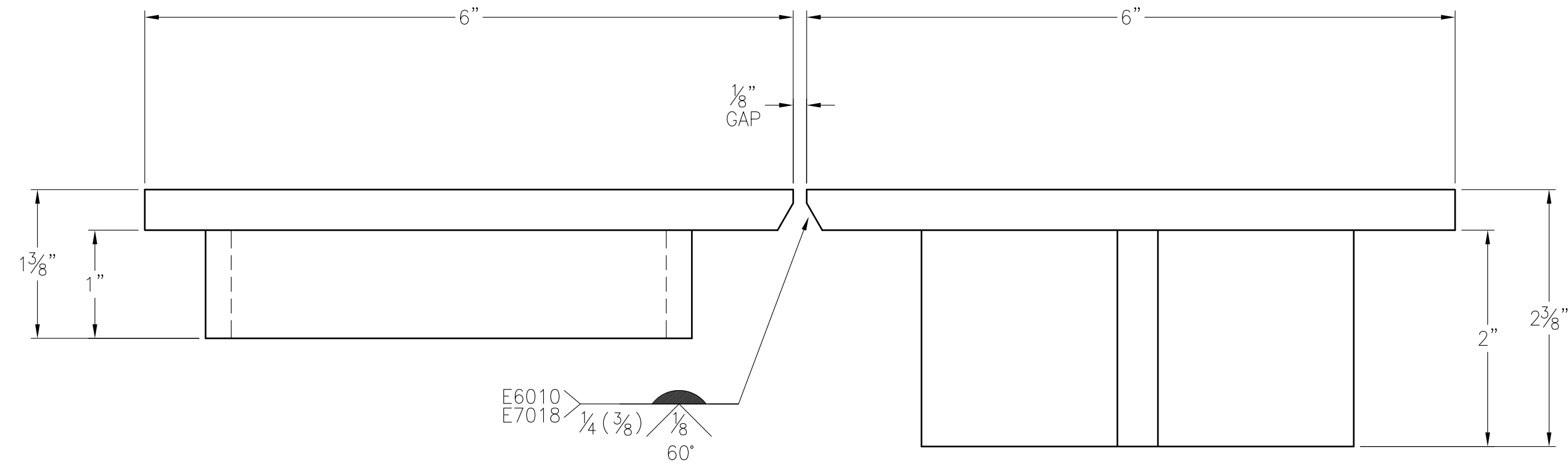

BRACKET "S"  
(1) REQ'D

- NOTES:
1. ALL WELDING TO BE SMAW
  2. ALL VERTICAL WELD PROGRESSION IS UP
  3. WELDMENT TO BE TACKED TOGETHER PRIOR TO HANGING IN VERTICAL POSITION
  4. ALL PIPE WELDING TO BE COMPLETED IN THE VERTICAL POSITION
  5. WELDMENT NUMBER SHALL BE IN UPPER RIGHT CORNER

ACAD/FILE: Bracket S  
 DRAWN BY: VFR 4/12/2017  
 CHECKED BY: initials xx/xx/2015  
 APPROVED BY: initials xx/xx/2015

**MORAN IRON WORKS, INC.**  
 11739 HWY. M-68 ONAWAY, MI 49765  
 1-989-733-2011

Industrial Arts Institute  
 Bracket  
 Onaway, MI.

REVISION NO.	REVISION DESCRIPTION
1	initials == DATE: xx/xx/xxxx
PROJECT MANAGER	PROJECT NUMBER
Keith Raymond	000000
SHEET TITLE	
Bracket "S"	
SHEET	
1 of 1	